

Quick Release Towing Systems

Mampaey Offshore Industries, The Netherlands

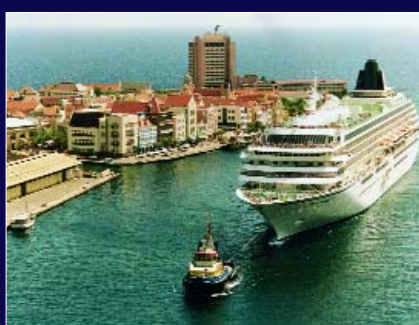

Over 100 Years of Safe and Reliable Towing Systems



The Mampaey Headquarters, The Netherlands



Mampaey Offshore Industries B.V. is the world leader in Safe Mooring and Towing Systems. Mampaey designs and manufactures a complete line of equipment for towing and mooring applications which are in use world-wide.



Gerard and Frank Mampaey

Since 1904 Mampaey has designed, developed and supplied the traditional harbour/mooring type towing hook. The increase in ship operations and stricter safety standards resulted in the next generation of towing and mooring equipment.

Quick Release Towing Hook

In 1950 the “Quick Release Disc Type Towing Hook” was designed and is still accepted world-wide as the leading standard by shipyards and tugboat operators.



Quick Release Towing Hook

The Mampaey Quick Release Disc Type Towing Hooks are specifically designed for towing with steel and nylon/polypropylene ropes. The disc will rotate freely until all rotation energy is dissipated. The Quick Release Disc Type Towing Hook is available, as standard, from 5 up to 100 M. Tonnes Safe Working Load. Higher loads are available upon request.

All our towing hooks can be supplied with various options such as

- Small fairlead for guiding manual release wire to bridge/wheelhouse.
- Mounting foundation for mounting the towing hook onto the ship's deck. The foundation can be welded or bolted onto the ship's deck, and/or horizontal brackets.
- Electric-Pneumatic Remote Control system.
- Electric-Hydraulic Remote Control system.
- Spring shock-absorber construction.
- Radial arm constructions and fixed radial constructions.
- Load Monitoring System for continuous measurement of towing loads.
- Anti-slip-rope device (“keepers”)



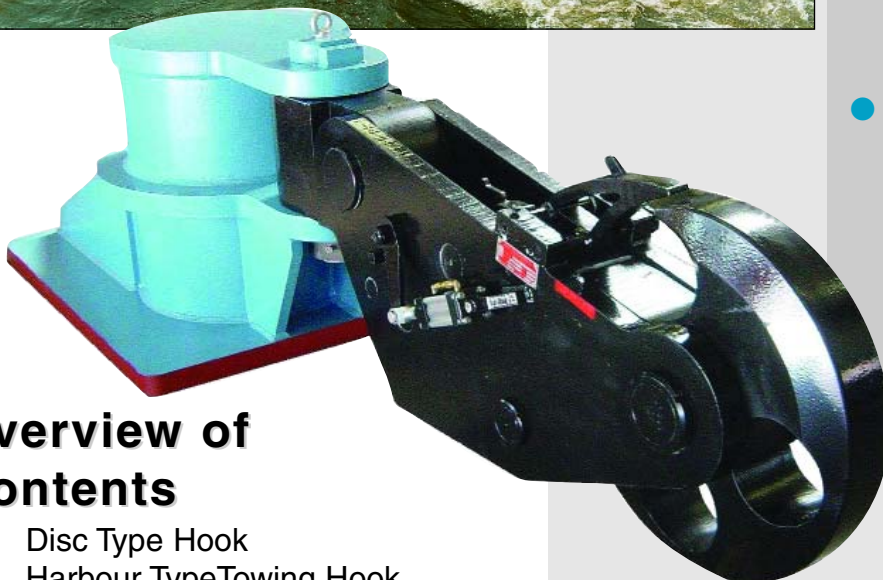

Advantages of using the Mampaey Towing Hook

- Safe handling and releasing with only a minimal manual effort of approx. 15 kg at full S.W.L.
- Long economic life of over 25 years.
- Minimum maintenance.
- Spare parts are not required for hooks without remote control.
- The Mampaey disc, free-rotating, type towing hooks are specially designed for towing with nylon and / or other p.p. ropes as well as steel /wire ropes.
- The disc rotating system avoids high release impact on the hook and foundation.
- The Mampaey towing hooks are free-swivelling so sliding / gliding plates are not required.

Overview of Contents

- Disc Type Hook
- Harbour Type Towing Hook
- Electric-Pneumatic Remote Control
- Electric-Hydraulic Remote Control
- Load Monitoring System
- Special Constructions
- Standard and Optional Items
- Other Mampaey Products

QUICK RELEASE DISC TYPE TOWING HOOK

The Quick Release Disc Type Type Towing Hooks are specifically designed for towing with nylon and / or other p.p. ropes as well as steel /wire ropes.

DCX 5/7 and 8/15

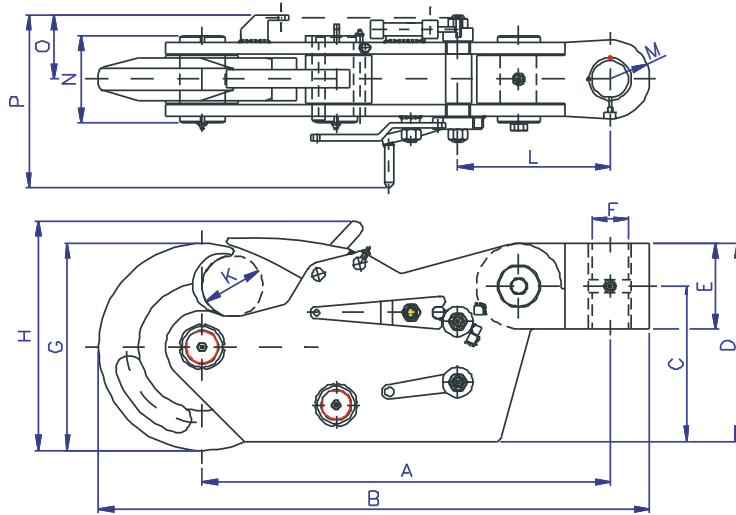

Type	S.W.L.	T.L.	R.L.	Wt.	A	B	C	D	E	F	G	H	K	L	M	N	O	P
DCX 5/7	70	140	70	66	512	712	185	235	100	45	280	291	65	125	60	112	97	260
DCX 8/15	150	300	150	145	670	905	255	325	140	60	340	377	100	250	65	144	106	284

DCX 18/25 upto 70/100

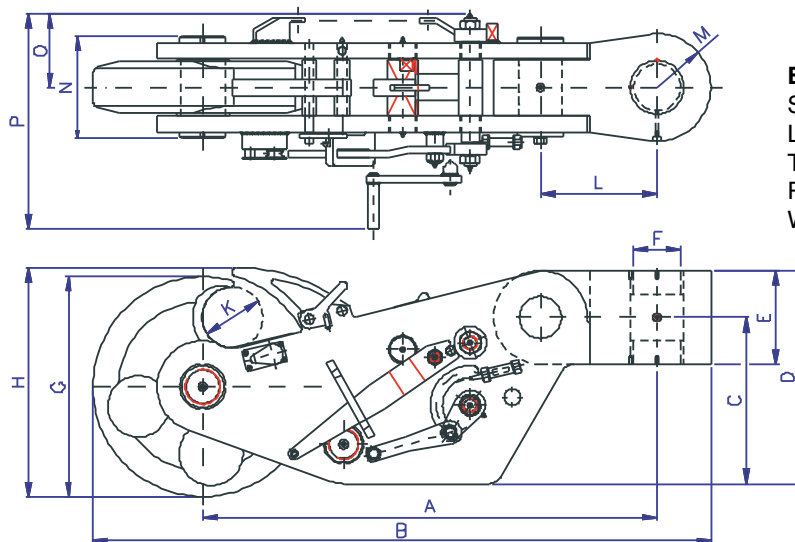

EXPLANATION:
 S.W.L.= Safe Working Load in kN
 T.L.= Testload in kN.
 R.L.= Releaseload in kN.
 Wt.= Weight in kilograms

Dimensions in millimeters

Type	S.W.L.	T.L.	R.L.	Wt.	A	B	C	D	E	F	G	H	K	L	M	N	O	P
DCX 18/25	250	500	250	345	923	1238	355	445	180	80	470	491	130	200	81	186	124	427
DCX 30/45	450	900	450	445	973	1323	355	455	200	100	470	490	130	200	115	218	158	462
DCX 50/65	650	1300	650	765	1173	1598	454	464	220	110	600	608	162	250	125	256	173	487
DCX 70/100	1000	1500	1000	1068	1290	1750	492	632	280	135	650	668	176	290	135	288	182	530

QUICK RELEASE HARBOUR TYPE TOWING HOOK

The Quick Release Harbour Type Towing Hooks are specifically designed for towing with steel / wire ropes.

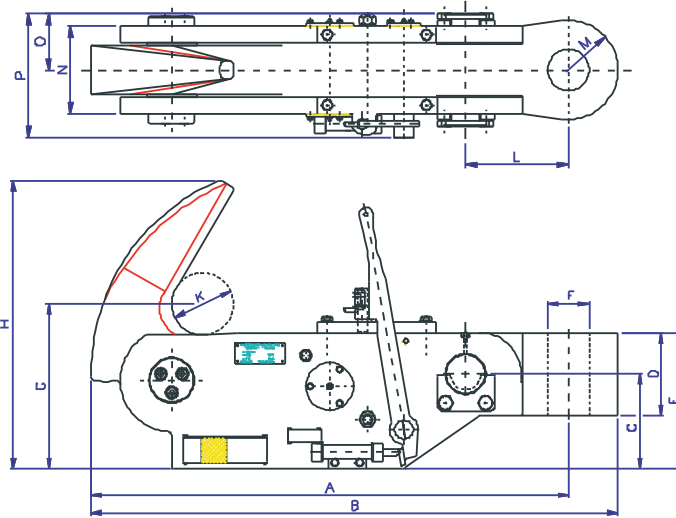

EXPLANATION:

S.W.L.= Safe Working

Load in kN

T.L.= Testload in kN.

R.L.= Releaseload in kN.

Wt.= Weight in kilograms

Dimensions in millimeters

Type	S.W.L.	T.L.	R.L.	Wt.	A	B	C	D	E	F	G	H	K	L	M	N	O	P
MXX 015	150	300	150	47	521	571	100	100	150	40	174	316	65	110	50	100	67	150
MXX 030	300	600	300	130	788	868	160	130	225	60	268	461	96	180	80	125	86	207
MXX 060	450	900	450	262	1023	1123	200	160	260	80	350	616	130	210	100	148	100	224
MXX 075	562	1125	562	320	1073	1183	200	180	290	90	350	616	130	250	110	170	110	245
MXX 100	1000	1500	1000	478	1159	1279	230	200	330	100	400	700	150	250	120	212	138	303

ELECTRIC-PNEUMATIC REMOTE CONTROL

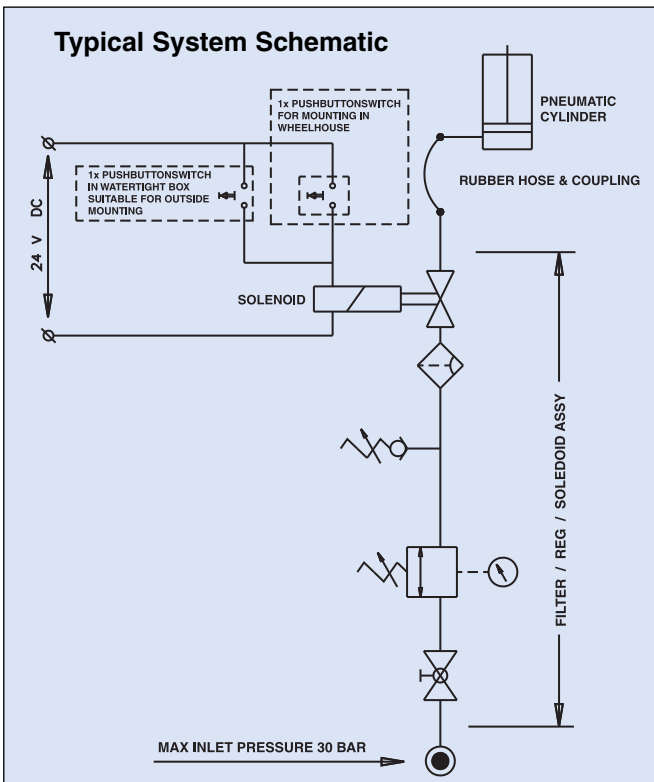

The Electric-Pneumatic Remote Control (EPR) allows for local and remote release of the hook. Operated from push-button(s) on the bridge or watertight push-button(s) on deck

areas the signal activates the solenoid permitting regulated compressed air from the vessels compressed air system to activate the pneumatic release cylinder.

ELECTRIC-HYDRAULIC REMOTE CONTROL



The Electric-Hydraulic Remote Control (EHR) has the same function as the EPR above, but operates a hydraulic release cylinder. Mampaey can offer either a complete hydraulic power pack or components permitting connection to the vessels hydraulic system.

Load Monitoring System

The load monitoring system consists of a load-cell, amplifier and remote display which continuously displays the applied load on the towing hook and gives a high load alarm at an adjustable alarm level.

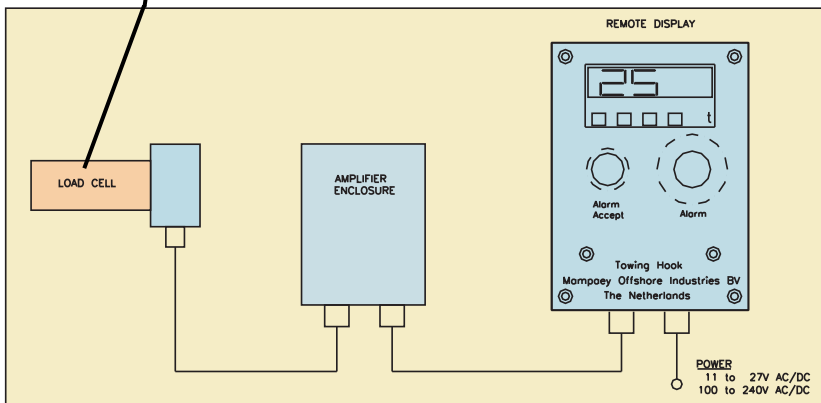

Special Constructions

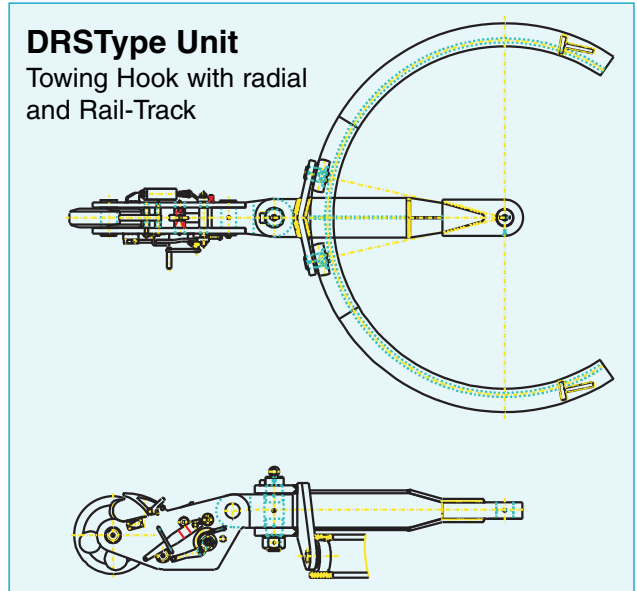
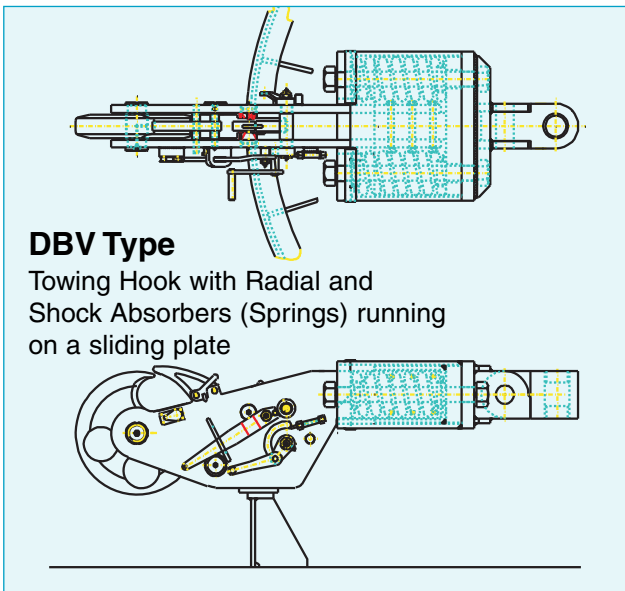
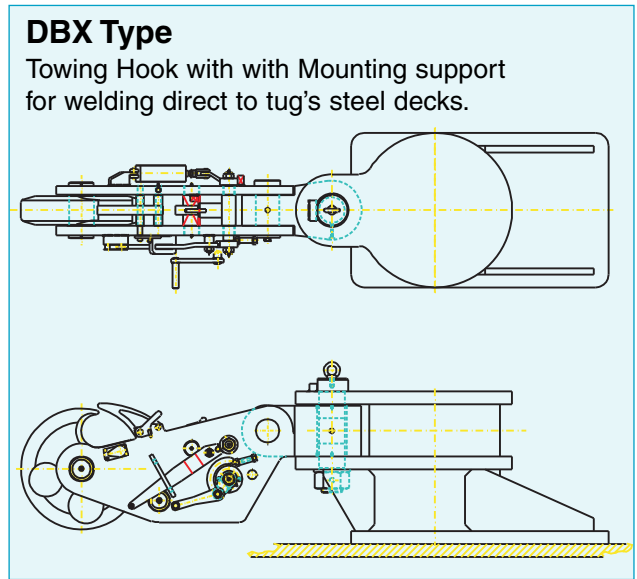
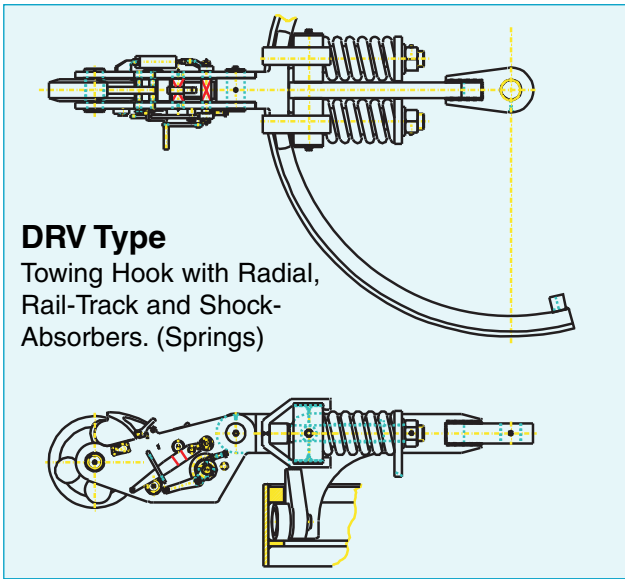

Standard and Optional Items

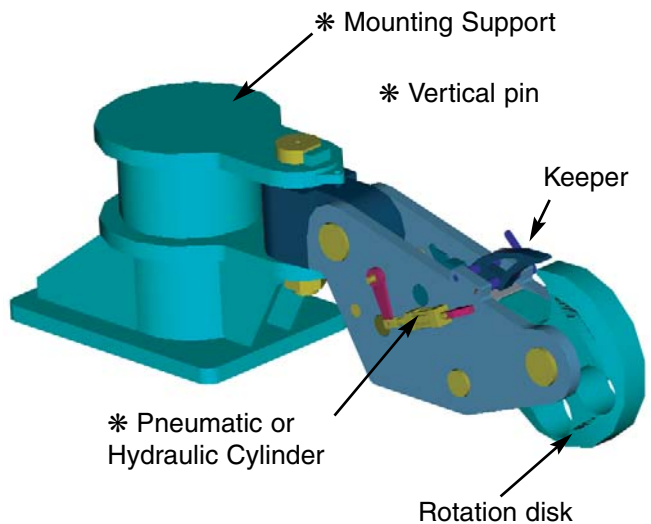
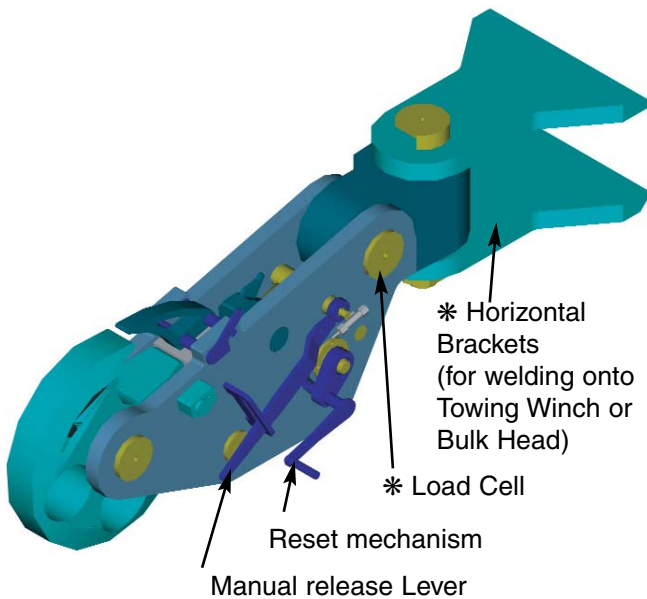

* Optional



Quick Release Mooring Hook Unit with Remote Control System and Load Monitoring System. (Standard from 15 up to 350 Tonnes S.W.L.)

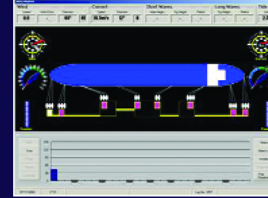

Mooring Load Monitoring and Berthing Approach Systems



Mooring Buoys with Quick Release Hooks



Hooks for FPSO's/FSO's executed as fixed or swiveling design. The hooks can be equipped with Remote Control Operation and Load Monitoring System. Standard execution from 200 up to 350 Tonnes S.W.L.

Postal address:
P.O.Box 667/698
3300 AR Dordrecht
The Netherlands
Tel.: +31 (0)78 617 33 22



Visiting address:
38 Jacobus Lipsweg
3316 BP Dordrecht
The Netherlands
Fax: +31 (0)78 617 52 11

E-mail: sales@mampaey.com - Internet: <http://www.mampaey.com>